

INDOOR UNIT

RSUB-162.A

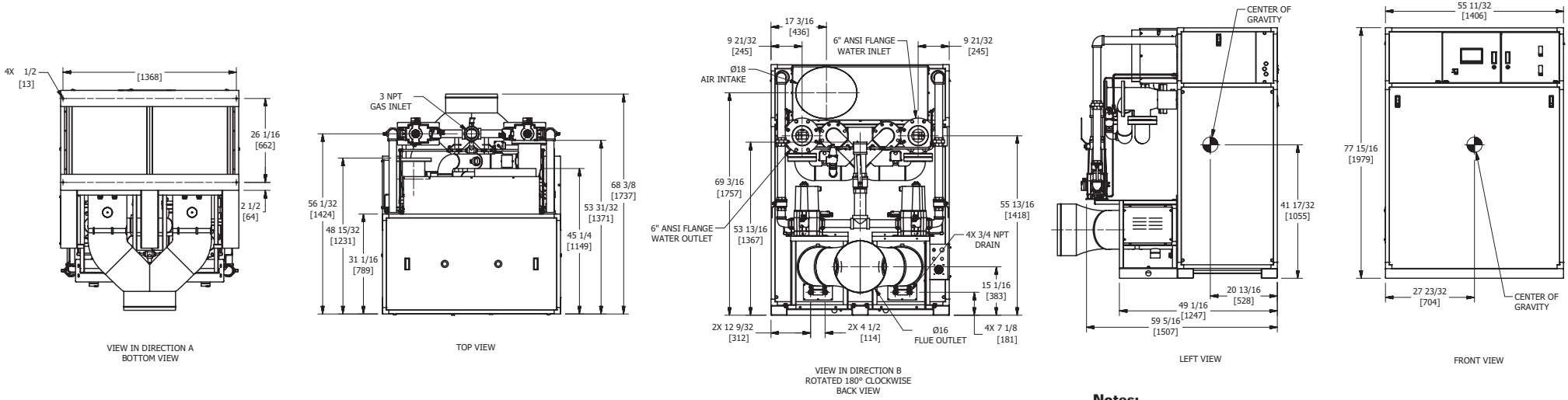

- Notes:**
1. Dimensions are approximate and should not be used to "rough-in" equipment.
 2. Dimensions are subject to change without notice.
 3. All dimensions are in inches (mm).

BOILER CERTIFIED RATINGS & CAPACITIES

Fuel Type	Natural/Propane Gas	Boiler FLA	26.9" @ 230V
Input BTU/hr.	10,000,000 / 2931 kW	Min. Gas Pressure Required	3.5" WC**
Output BTU/hr.	8,510,000 / 2494 kW	Max. Gas Pressure Allowed	14" WC
Electrical Requirements	(L1, L2, L3, GND) 230 VAC / 3PH / 60Hz	Operating Weight	3641 lbs / 1652 kgs

BOILER TEMPERATURE RISE / PRESSURE DROP†

30°F / 16.7°C				35°F / 19.4°C			
Flow Rate		Pressure Drop		Flow Rate		Pressure Drop	
GPM	L/s	Ft	kPa	GPM	L/s	Ft	kPa
567.6	35.8	33.0	98.7	486.5	30.7	24.3	72.5

† Cupronickel heat exchanger standard.

BOILER / WATER HEATER TRIM & CONTROLS

Main Gas Valve Body (2)	Dungs MBC 4000	High Limit (Manual Reset)	Jumo
Firing Valve (2)	Honeywell B200T1066 2"	High Limit (Auto Reset)	Jumo
Main Ball Valve	3"	Blocked Flue Switch	HUBA
Manual Pilot Valve	1/4" Honeywell B528	Air Switch	HUBA
Pilot Regulator	White-Rodgers 25m	Blower Motor (2)	American Fan 5 HP - FLA 9
Ignition Control (2)	Honeywell RM7895C	Relief Valve - MB (2)	1-1/2" x 2" set @ 50 psi
Operating Control	HeatNet®	Flow Switch (2)	ITT FS8W

A.S.M.E.

ASME Sect IV Htg Surface	1088.6 Sq Ft / 101.1 Sq M	Design Data	Max. 160 psig & 250°F
Water Volume	31.2 gal / 118.24 Liters		

* Add circulator amps.

** For incoming gas pressures lower than 3.5" W.C. natural or propane, consult factory.

REP FIRM _____
SUBMITTED BY _____
JOB NAME _____
ARCHITECT _____
ENGINEER _____
CONTRACTOR _____
DATE _____

FUTERA XLF 10000

Category I, II or IV Appliance
(see Installation and Operation Manual for venting information)



A Division of Mestek, Inc.
Westfield, MA 01085
(413) 568-9571